

Einführung in die Informationsverarbeitung

Øyvind Eide

Woche 12
Graphen
Modellierung

oeide@uni-koeln.de
<http://idh.uni-koeln.de>



Ausgangspunkt I

Möglichkeit möglichst vieler derartiger Probleme auf eine einzige Klasse von Vorgehensweisen zurück zu führen.

Abstraktion

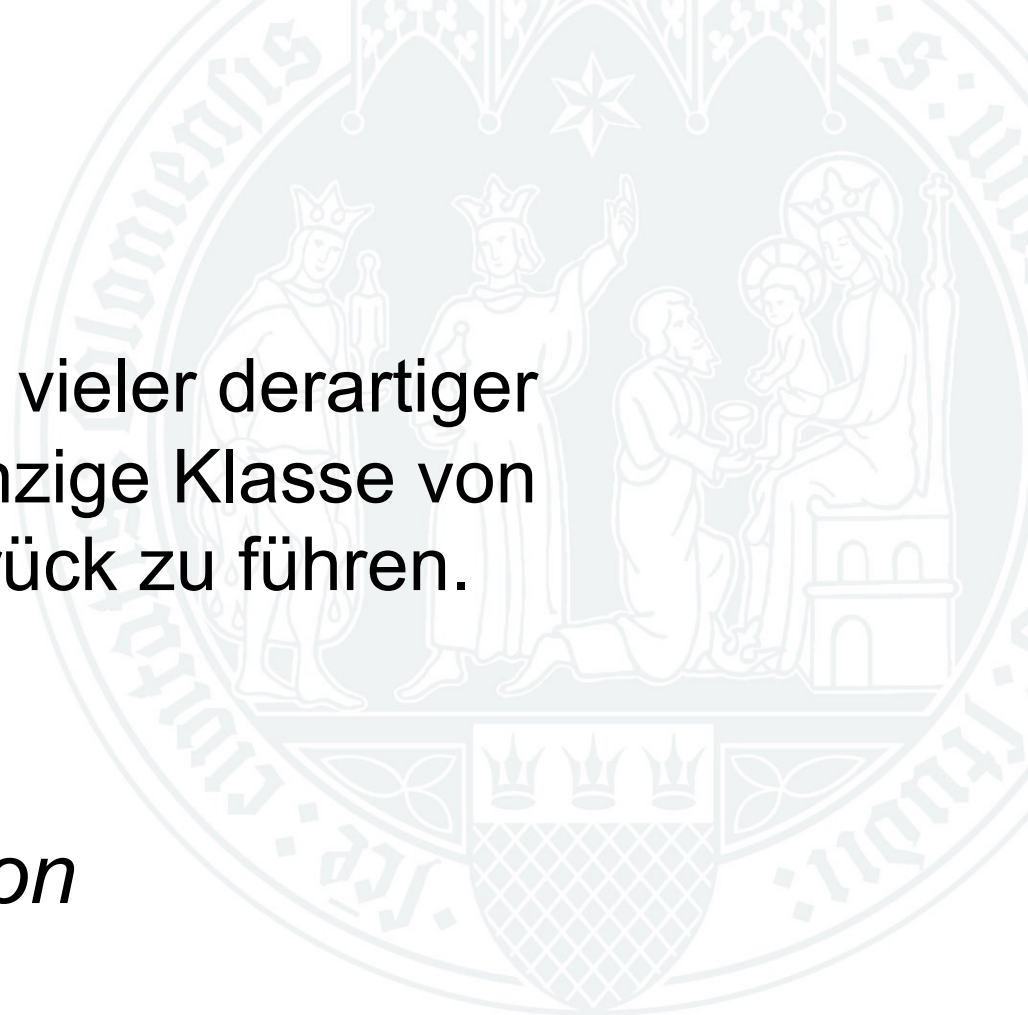

Ausgangspunkt II:

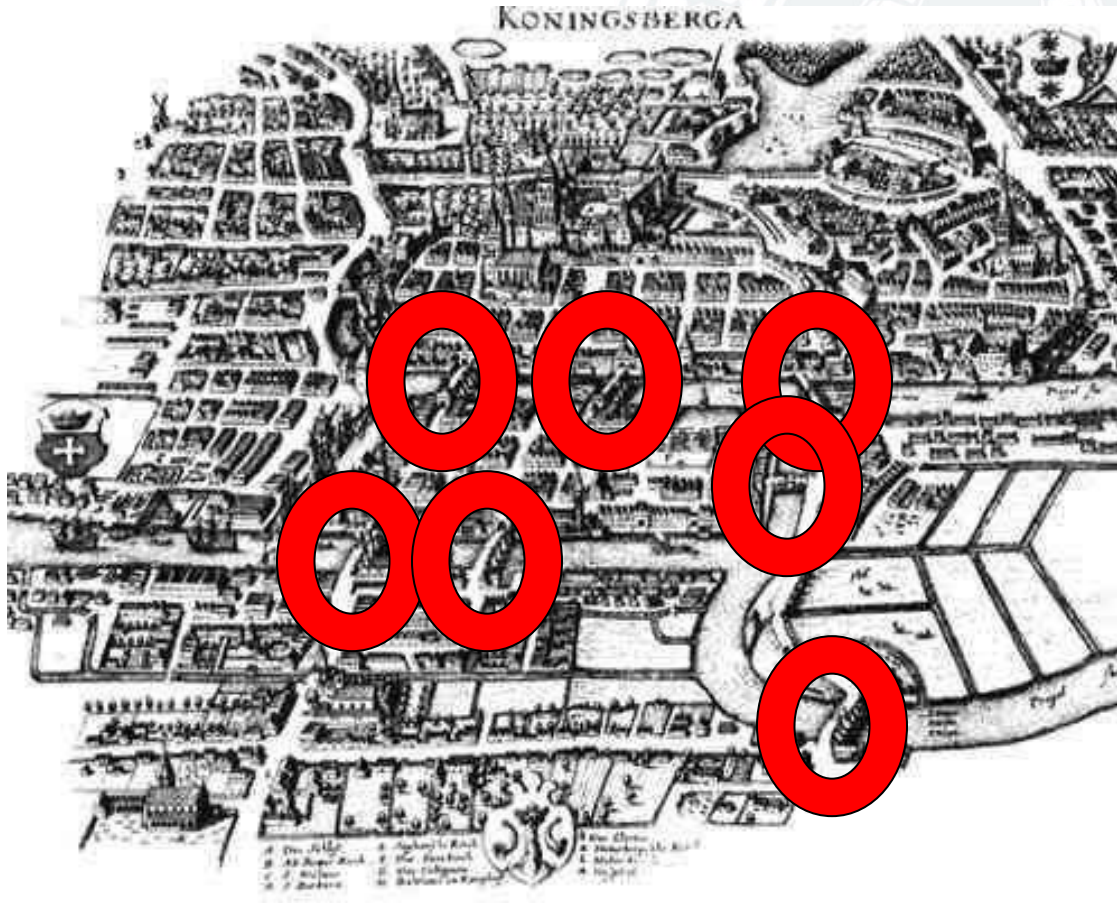

Königsberger Brückenproblem

Frage: Möglichkeit, alle 7 Brücken hintereinander so zu überqueren, dass jede genau *einmal* – also *nicht* mehrmals – überquert wird.

Leonhard Euler (1707 bis 1783).



Abstraktion I

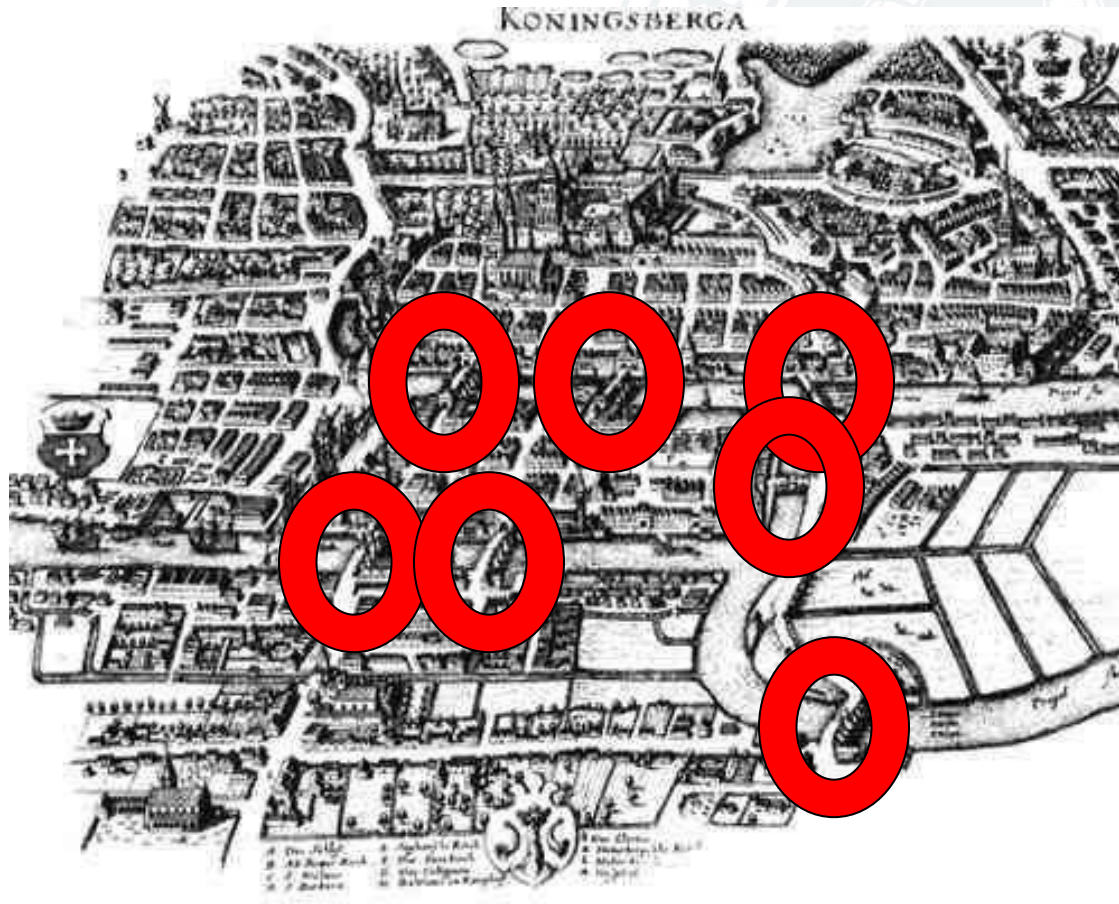

Abstraktion II

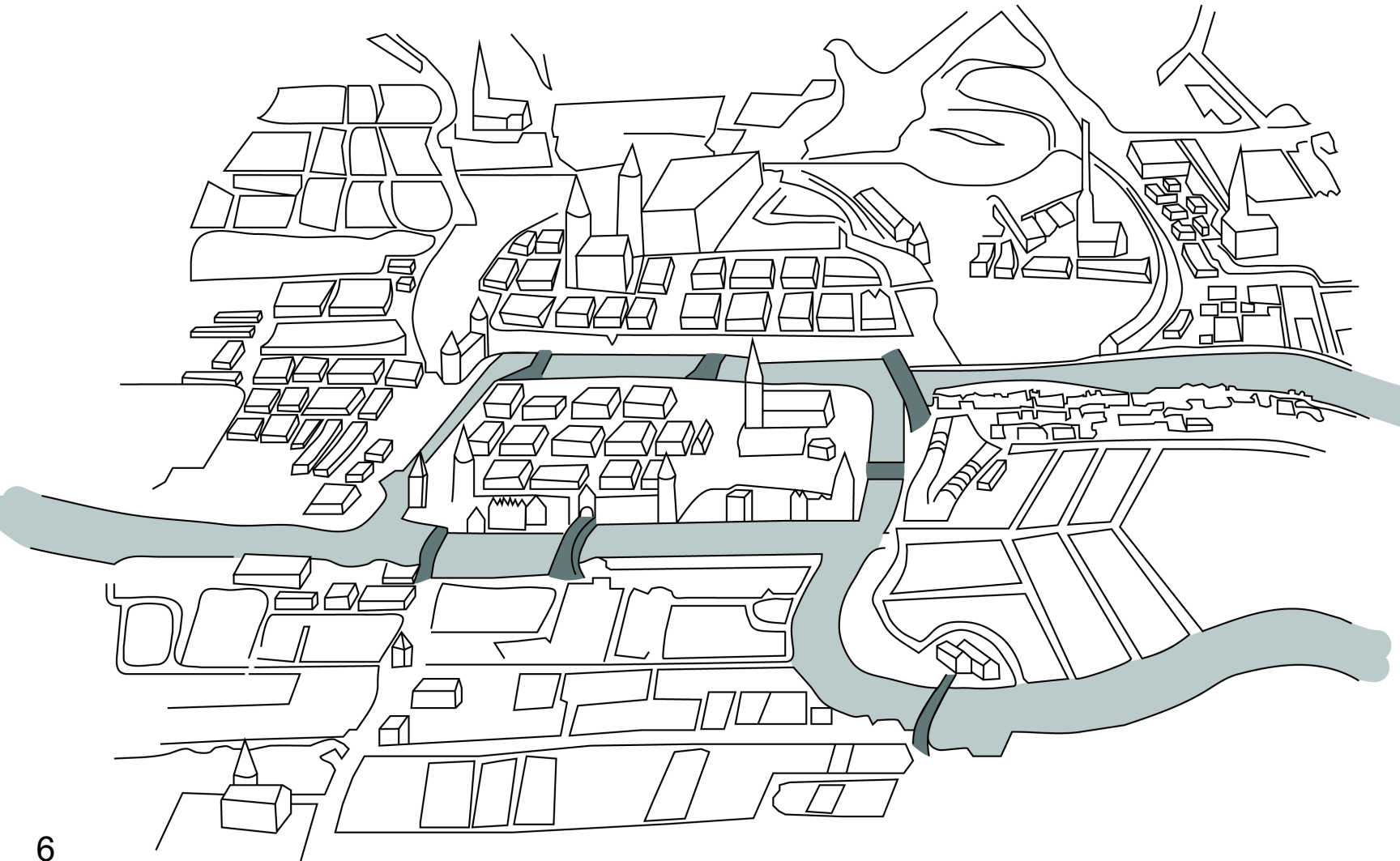

Abstraktion III

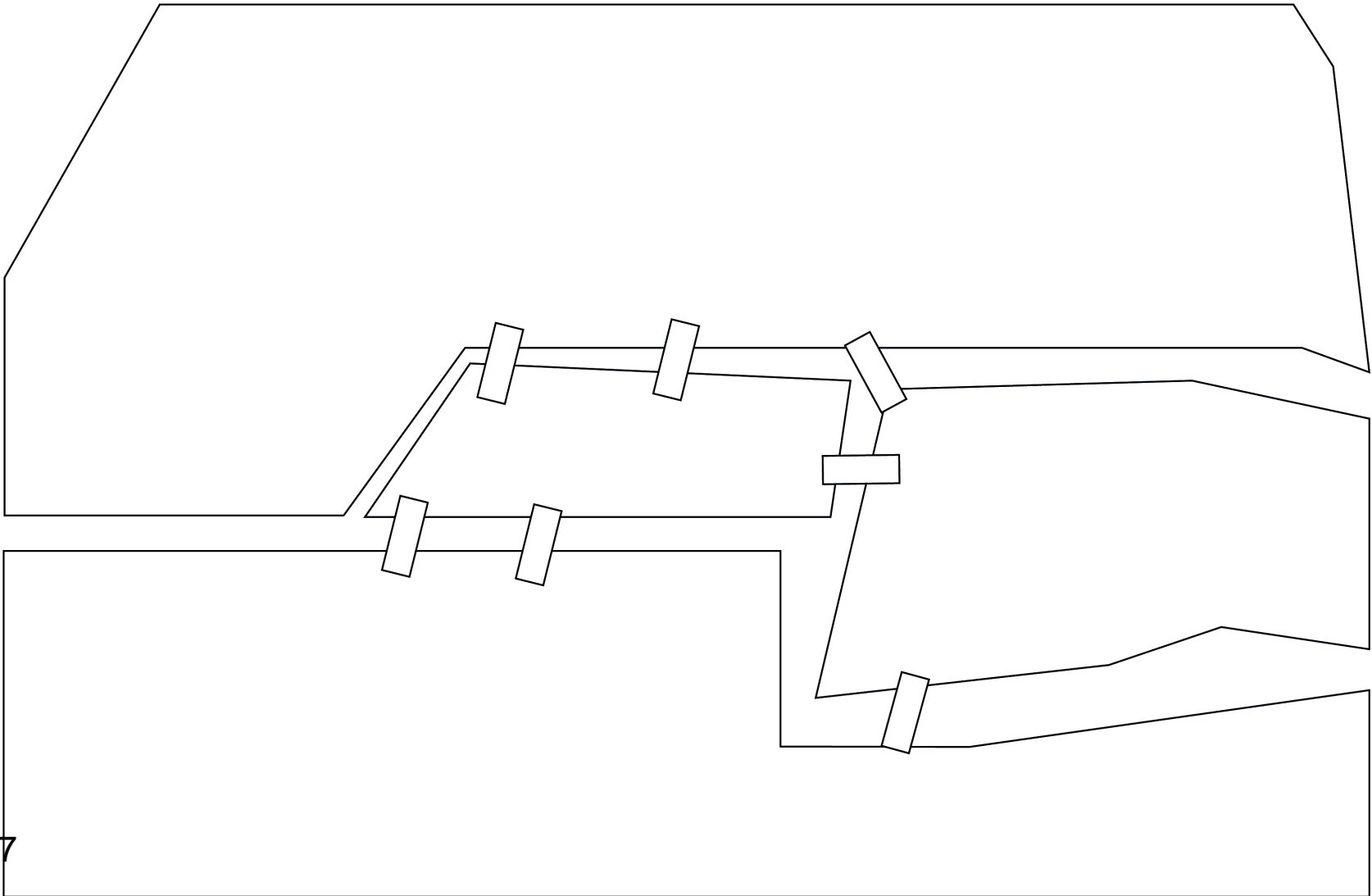

Abstraktion IV

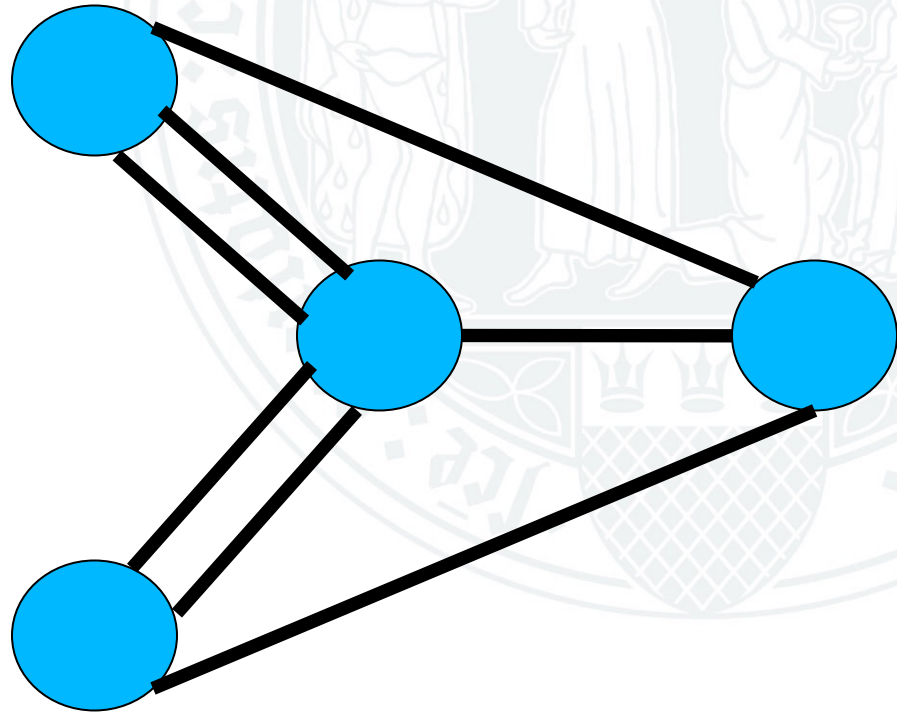

„Ein Graph“

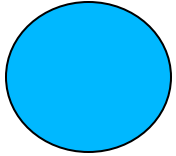

Knoten
(Vertex, Nodes)

Kanten
(Edges)

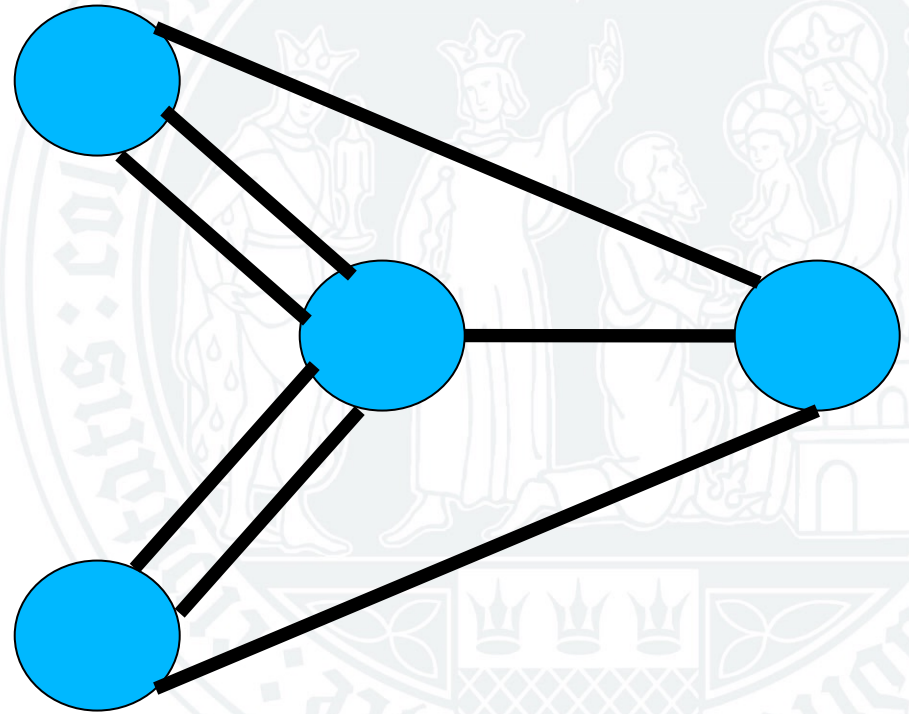

Definition des Problems

Ein Graph \mathbf{G} heißt *Eulerscher Graph*, falls es einen geschlossenen einfachen Kantenzug gibt, der jede Kante von \mathbf{G} enthält. Ein solcher Kantenzug heißt dann *Eulerscher Kantenzug*.

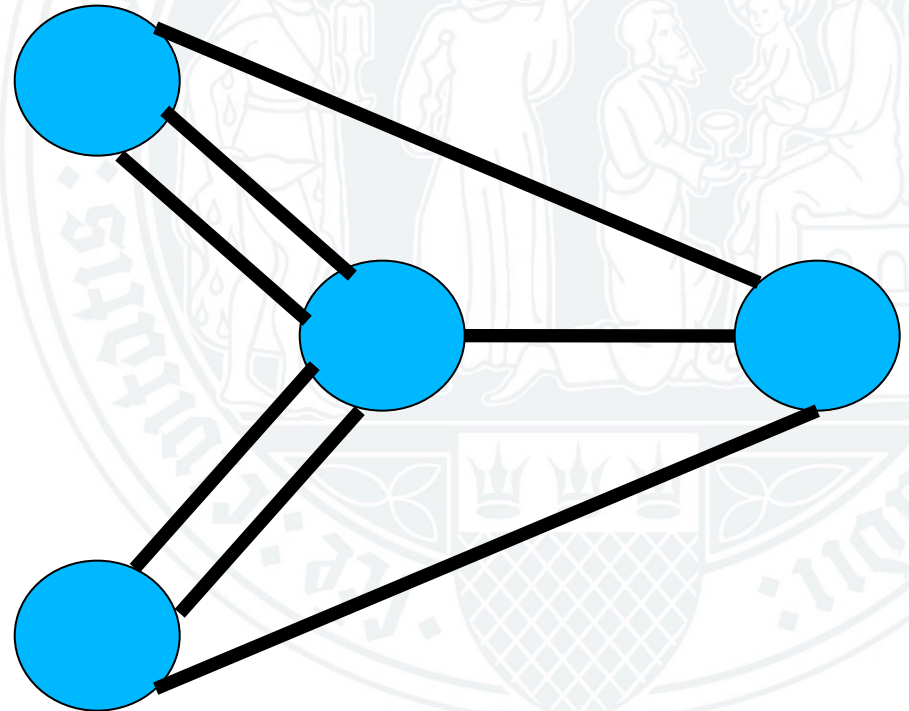

„Lösung“ des Problems

Sei \mathbf{G} ein zusammenhängender Graph. Genau dann ist \mathbf{G} ein *Eulerscher Graph*, wenn jeder Knoten von \mathbf{G} geraden Grad hat.

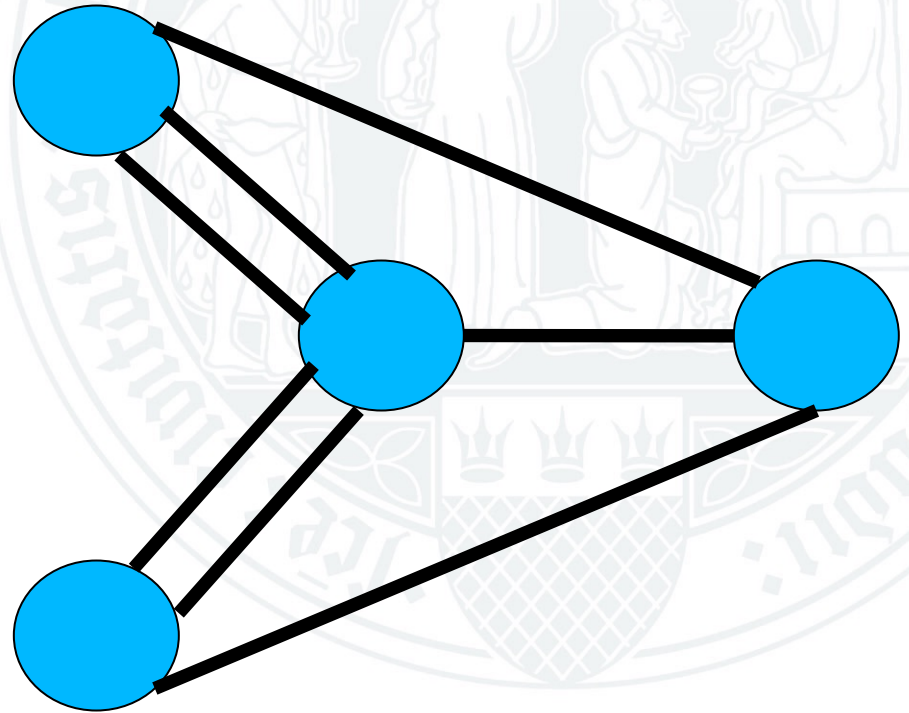

Ziele der Graphentheorie

(1) Erlaube Aussagen
über auf Graphen
zurückführbare
inhaltliche Probleme.

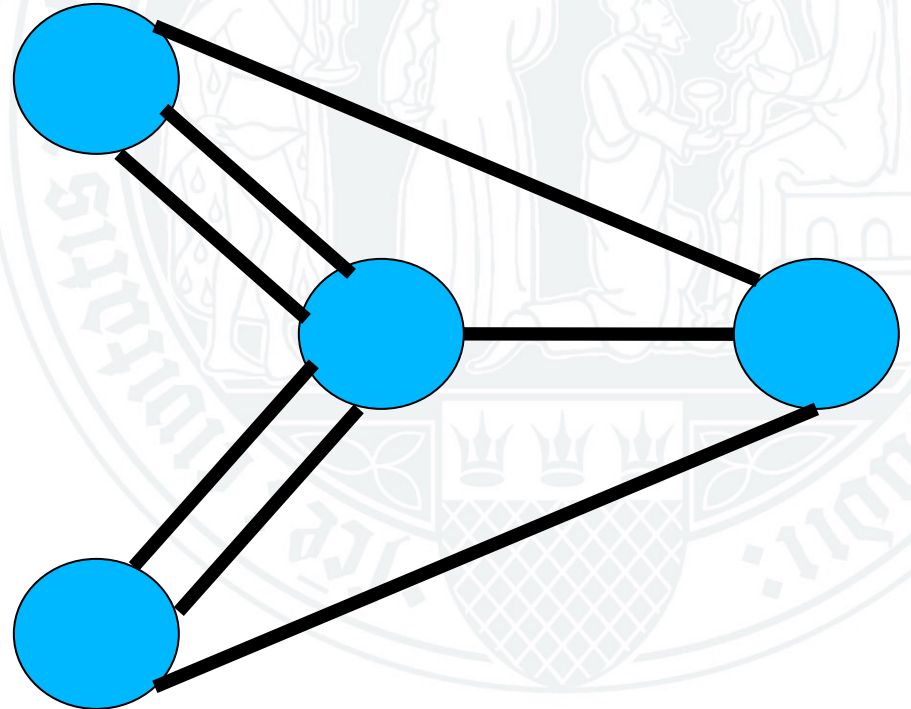

Ziele der Graphentheorie

Kopf:



Atom 1

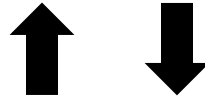

Atom 2

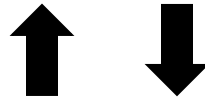

Atom 3

(2) Beschreibe direkt die Eigenschaften von Listen, die wir vorher als eine der grundlegenden Datenstrukturen kennengelernt haben.

Schwanz:



Definitionen I

Einfacher,
ungerichteter Graph.

Auch „schlichter
Graph“.

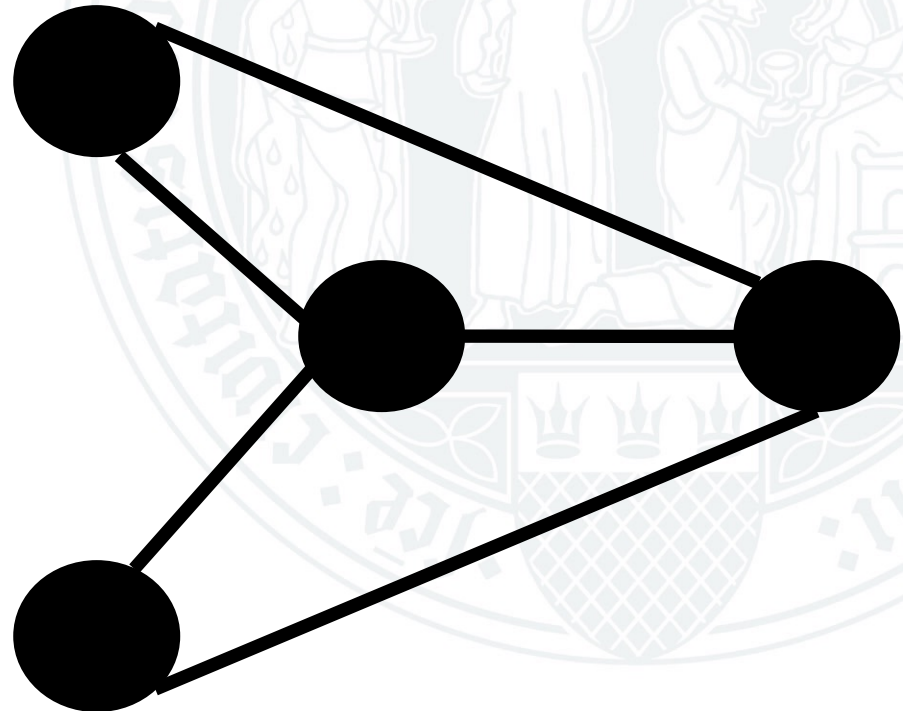

Definitionen II

Einfacher, gerichteter
Graph.

Kanten hier:
„gerichtete Kanten“,
Bögen oder *Dikanten*.

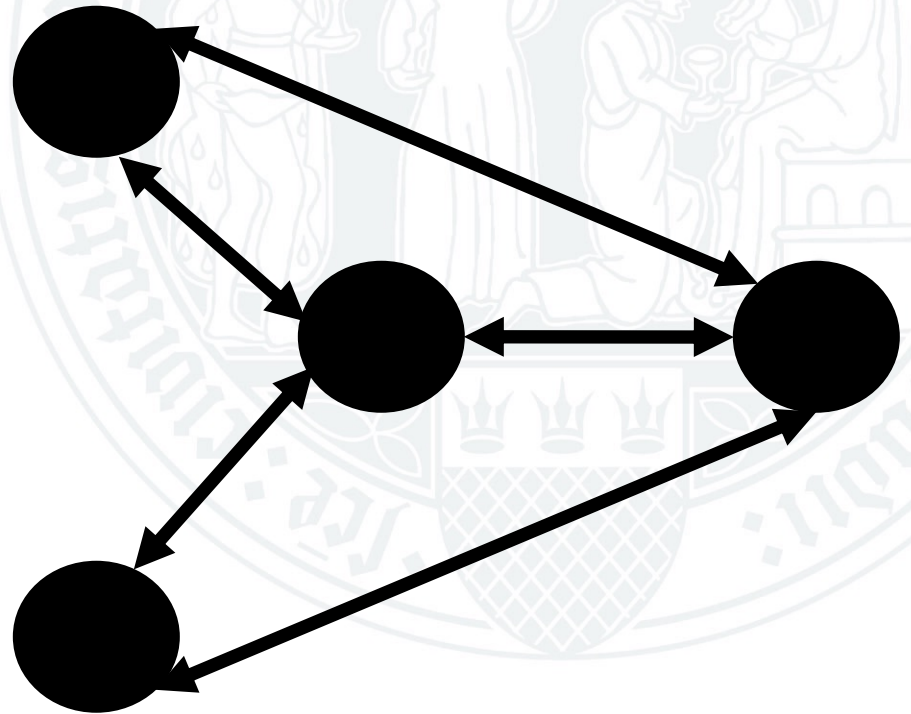

Definitionen III

Ungerichteter Graph
mit Mehrfachkanten,
auch „Multigraph“.

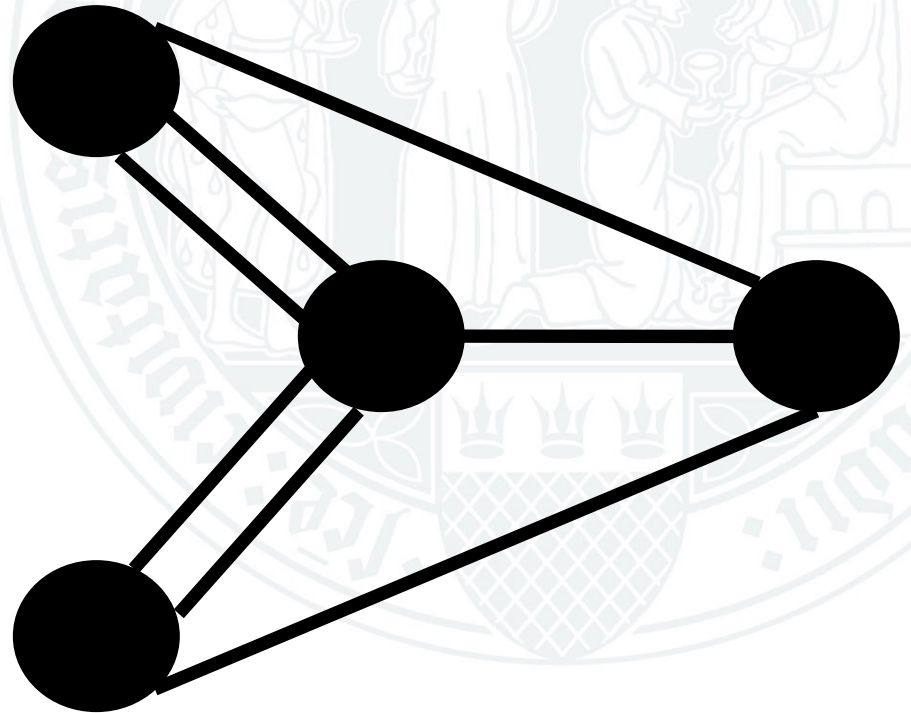

Definitionen IV

Knotengefärbter
Graph.

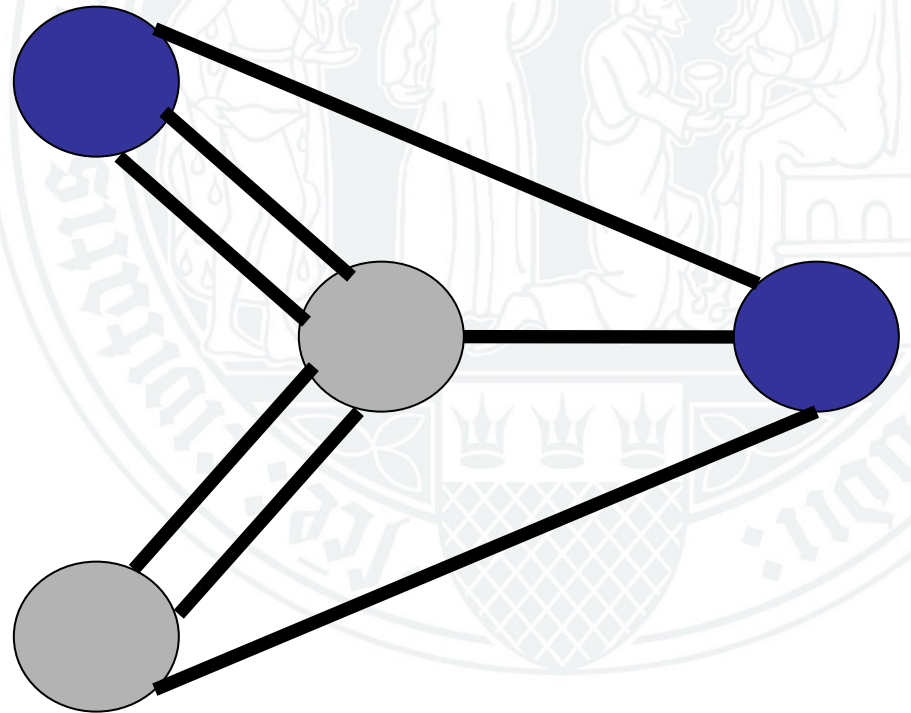

Definitionen V

Kantengefärbter
Graph.

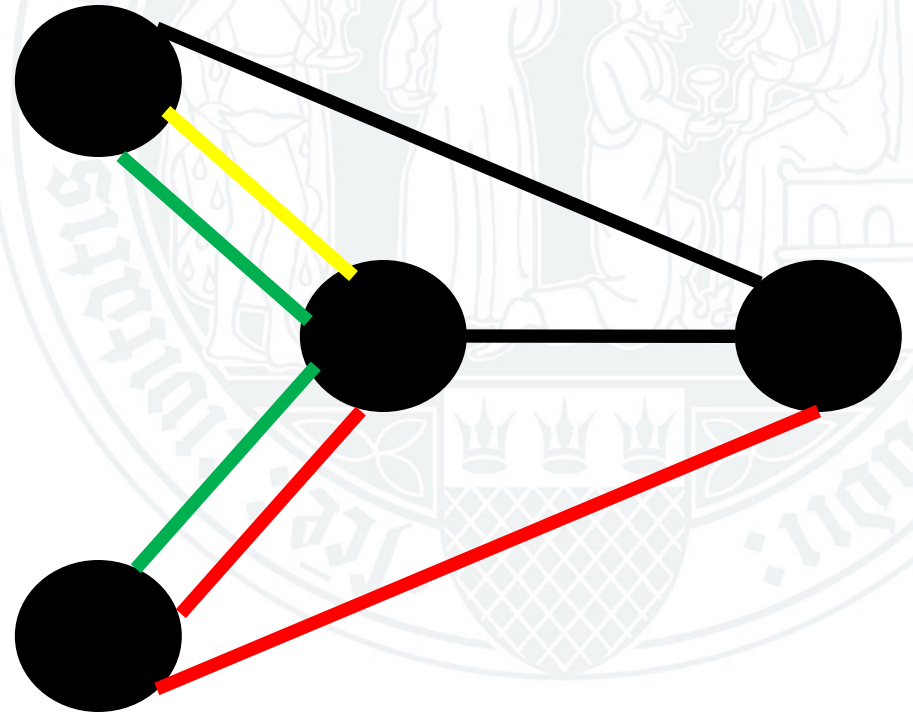

Definitionen VI

Ein verbundener
- oder
zusammenhängender -
Graph.

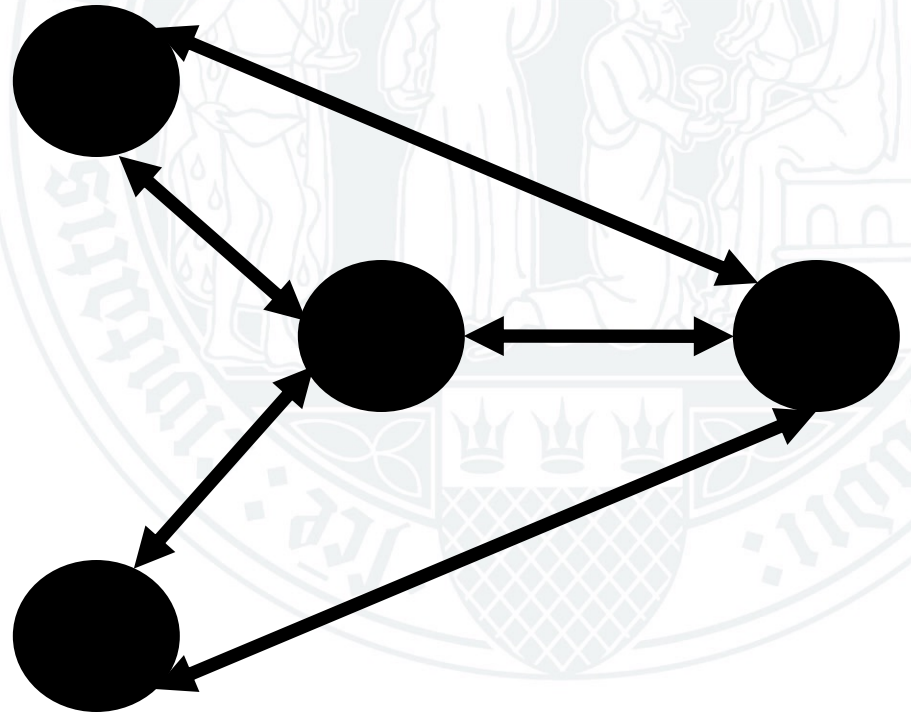

Definitionen VII

Ein unverbundener -
oder
unzusammenhängender
- Graph.

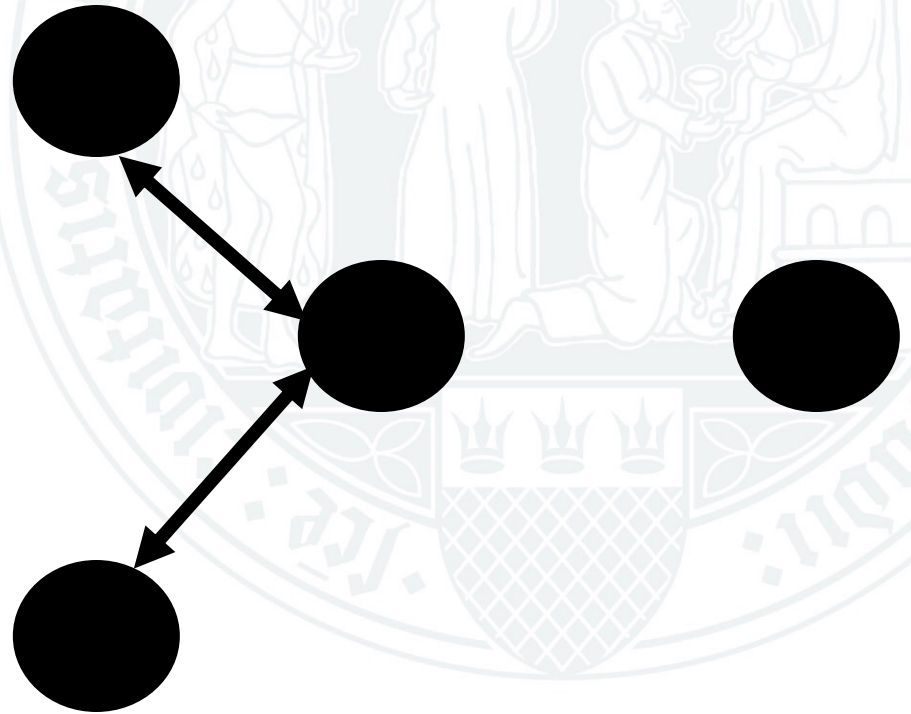

Definitionen VIII

Ein Graph mit einer
Schleife

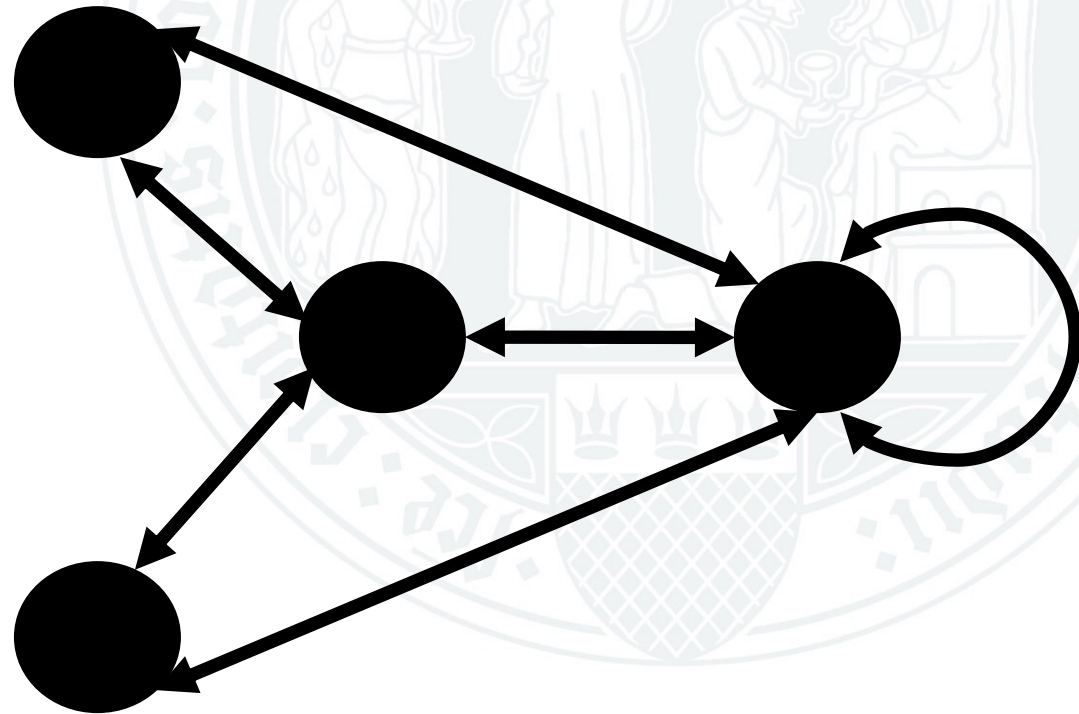

Definitionen IX

Ein Graph mit einem
Zyklus.

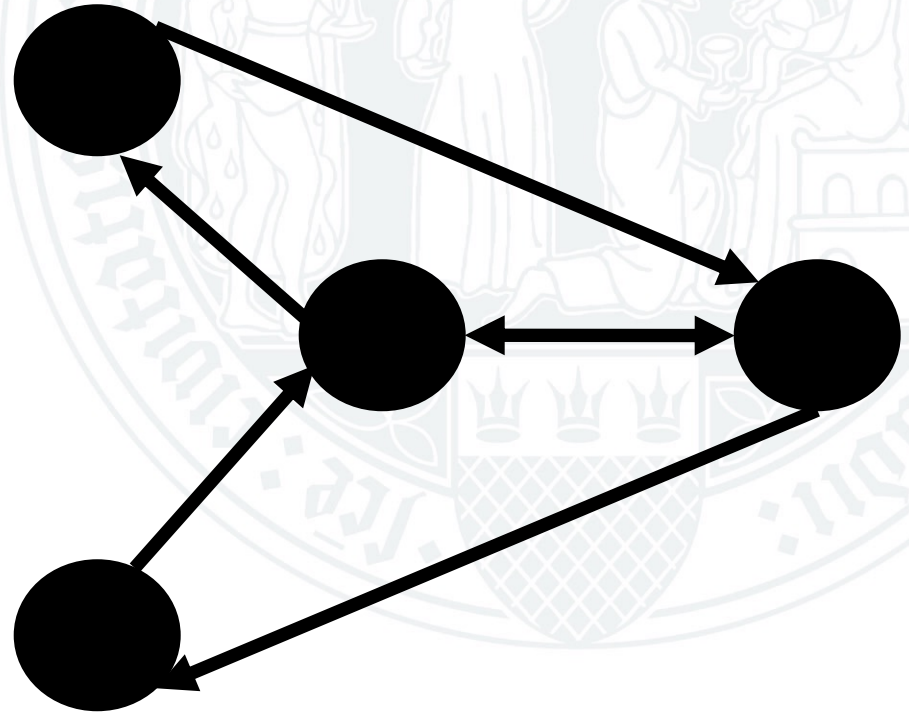

Definitionen IX

Ein Graph mit einem Zyklus.

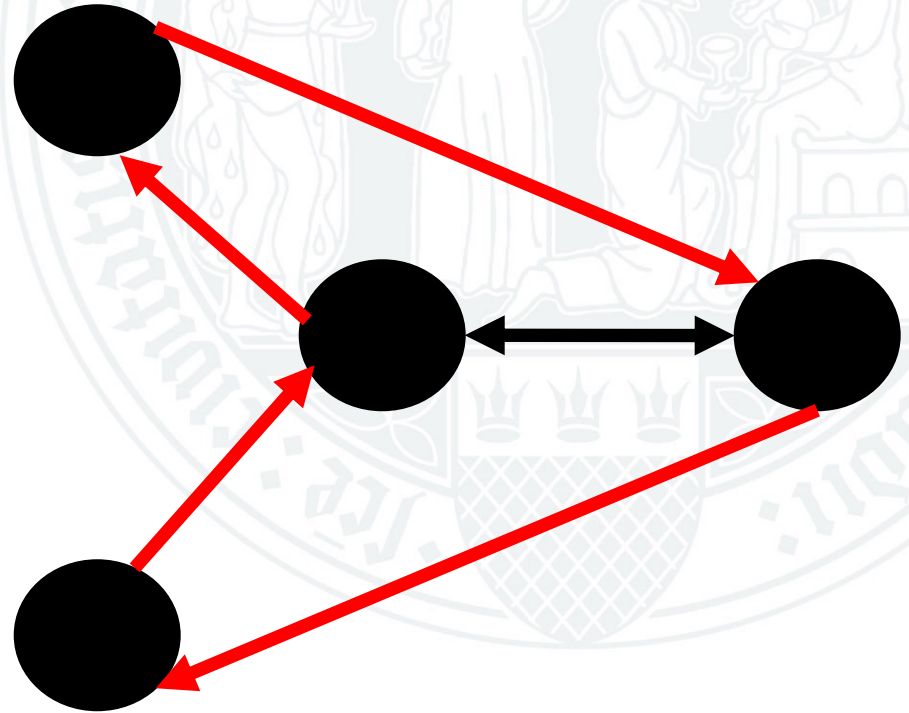

Beziehung: Graphen und Matrizen

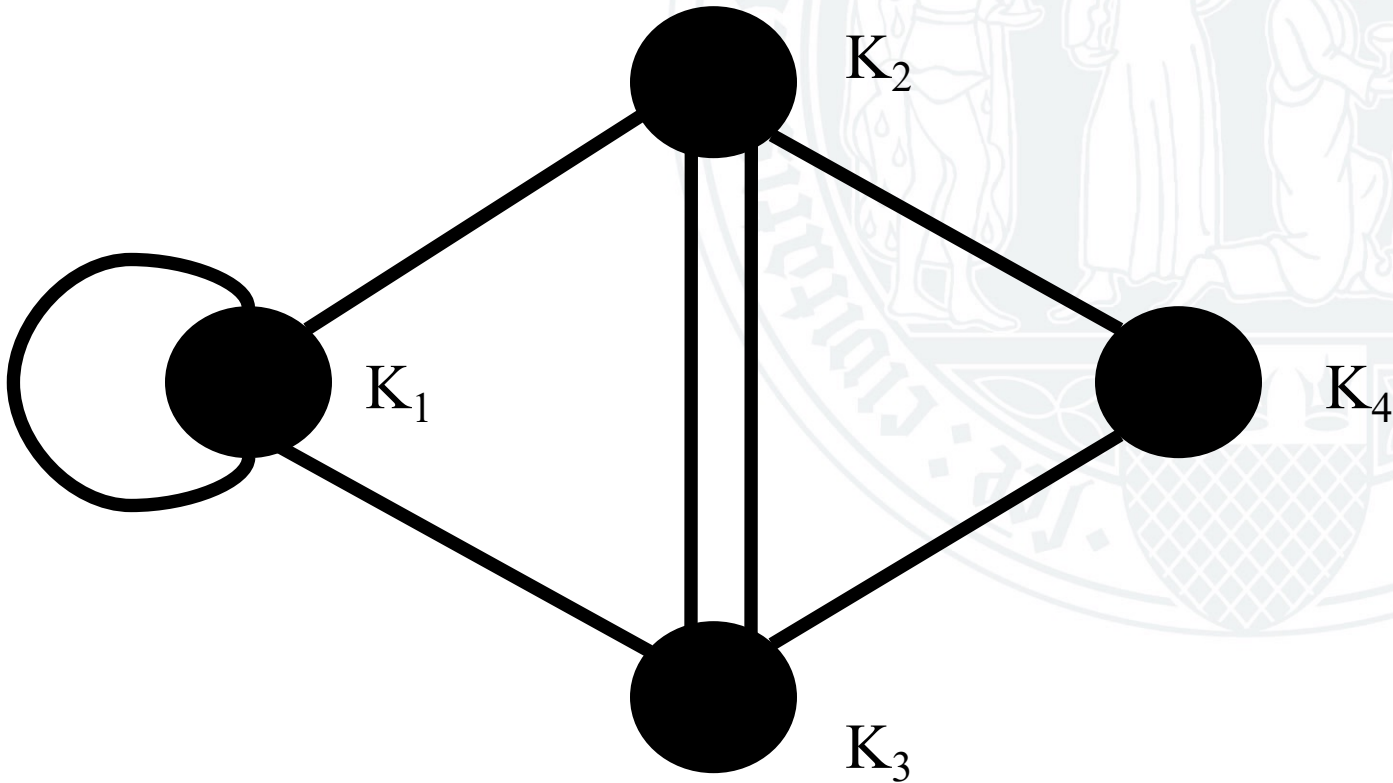

Beziehung: Graphen und Matrizen

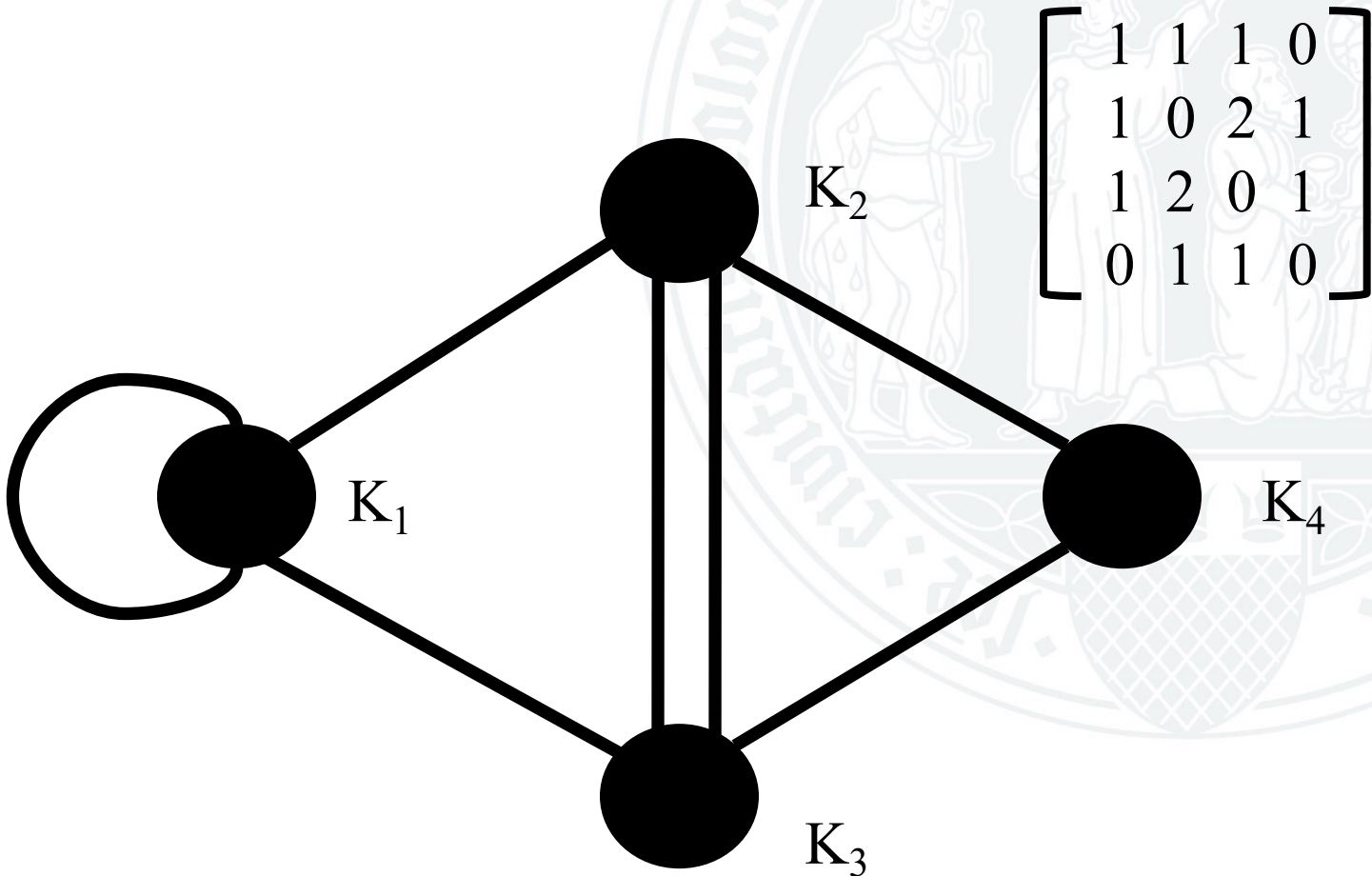

Beispiel

Hochspannungsnetz in Deutschland



Verbindungen

Startseite | Kontakt | Häufige Fragen | A A A

Angebotsberatung
Fahrplan & Buchung
Services
BahnCard
Geschäftsreisen
Urlaub
Meine Bahn

✓ Suche
 Auswahl
Ticket & Optionen
Zahlung
Prüfen & Buchen
Bestätigung

Ihre Reisedaten

Hinfahrt von Abfahrt Ankunft Aktualisieren

nach

Reisende 1 Erwachsener, 2. Klasse → Weitere Angaben ändern → Neue Anfrage

Häufige Fragen

- Wo finde ich Sparpreise?
- Warum finde ich mein Verbund-Ticket auf bahn.de nicht?
- Wieso wird bei manchen Verbindungen "Preisauskunft nicht möglich" angezeigt?
- **Alle häufig gestellten Fragen**

Wählen Sie eine Verbindung

Ihre Hinfahrtmöglichkeiten - sortiert nach Druckansicht

Bahnhof/Haltestelle	Datum	Zeit / Prognose	Dauer	Umst.	Produkte	Preis für alle Reisenden*	
		↑ Früher					Normalpreis
Köln Messe/Deutz Gl.11-12 Göttingen	Do, 11.12.14 Do, 11.12.14	ab 07:44 an 10:41	2:57	1	ICE	Verbindung liegt in der Vergangenheit → Rückfahrt hinzufügen	
Köln Hbf Göttingen	Do, 11.12.14 Do, 11.12.14	ab 07:48 +0 an 11:15	3:27	1	ICE	86,00 EUR → Rückfahrt hinzufügen	
Köln Hbf Göttingen	Do, 11.12.14 Do, 11.12.14	ab 07:48 +0 an 11:53	4:05	2	ICE, RE	86,00 EUR → Rückfahrt hinzufügen	

↓ Später



Travelling salesman

Besuche jede Stadt, aber
keine zweimal – auf
möglichst kurzem Weg.

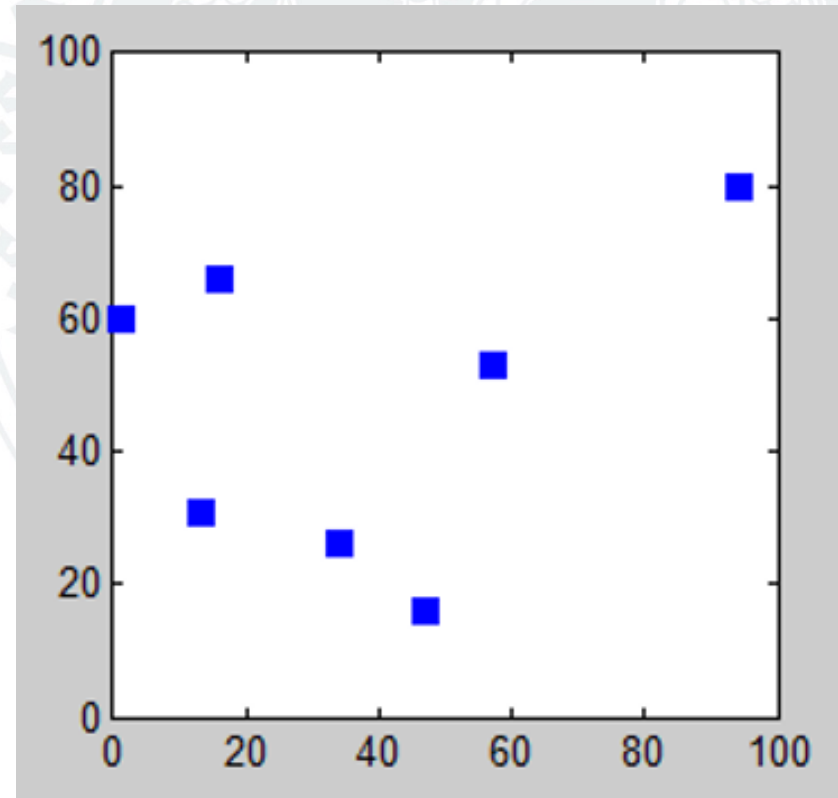

Travelling salesman

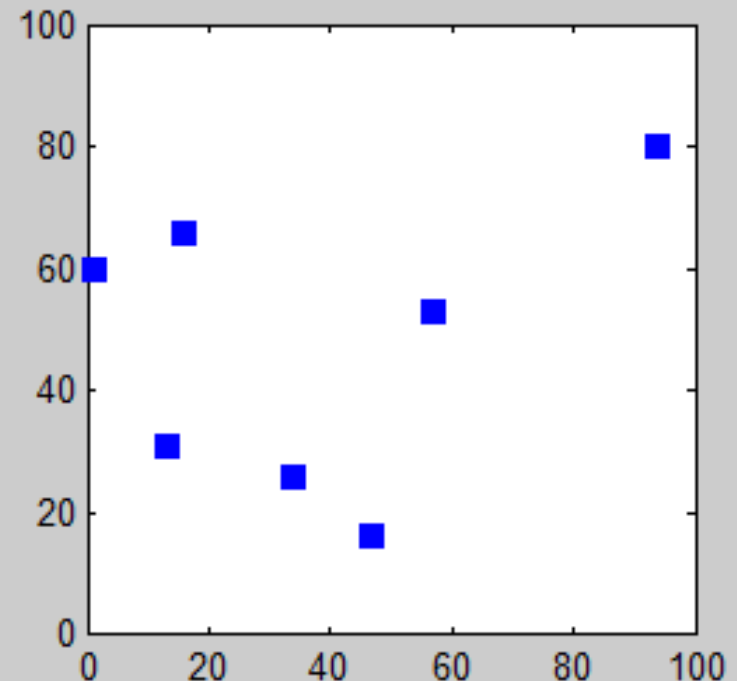
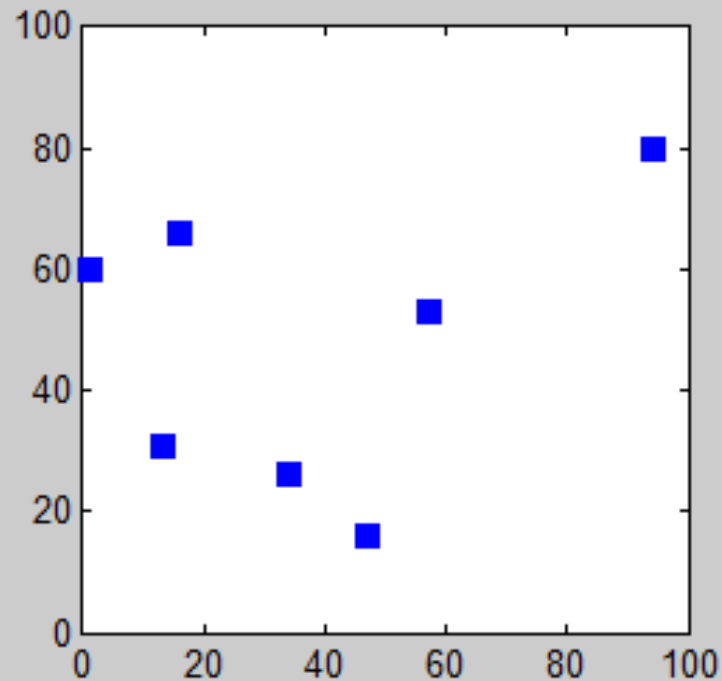

“Brute force” Anzahl der Permutationen: $(7-1)!/2 = 360$



Travelling salesman

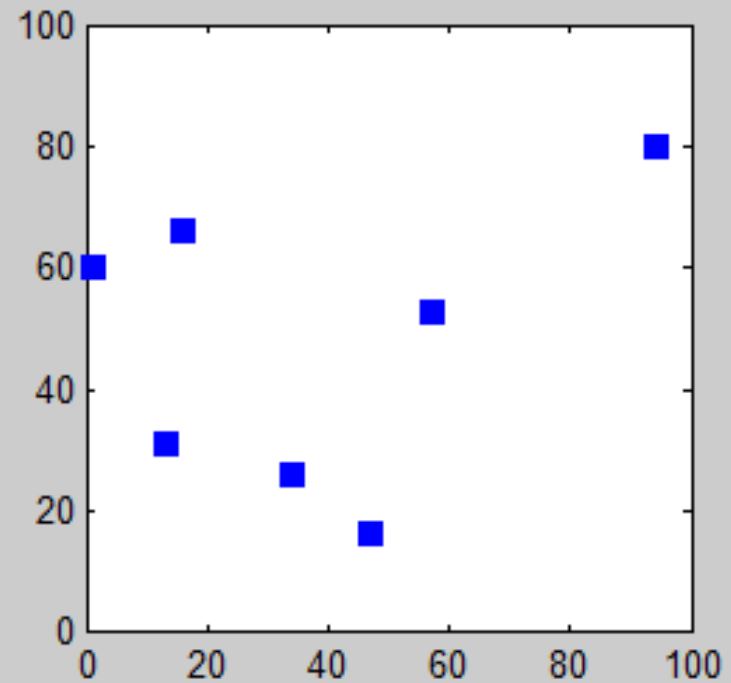
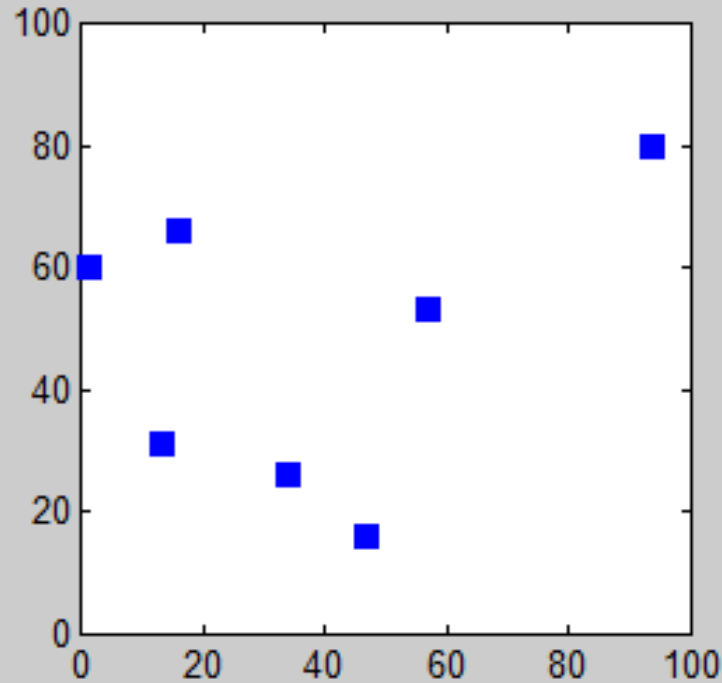

“Branch and Bound” Anzahl der Permutationen < “Brute Force”



Travelling salesman

“Nearest Neighbour”
Ergebnis abhängig
vom Startknoten

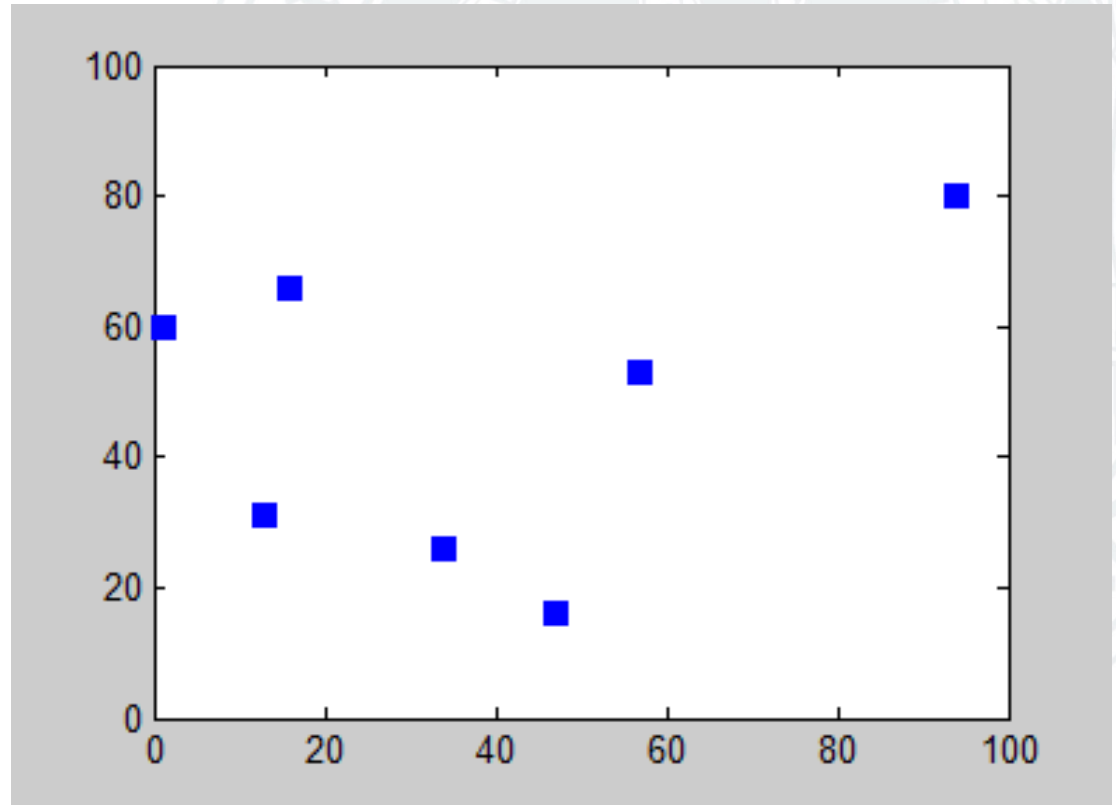

Anwendungen ...

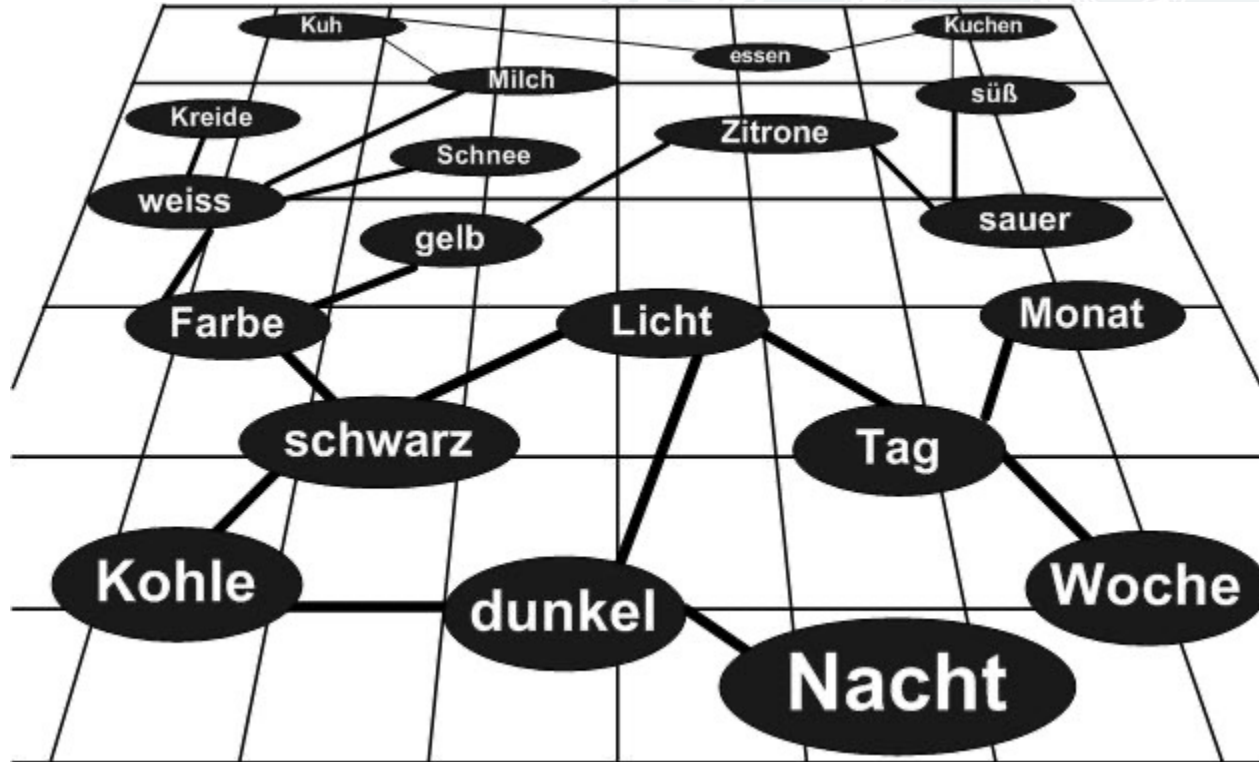

Semantisches Netz

Anwendungen ...

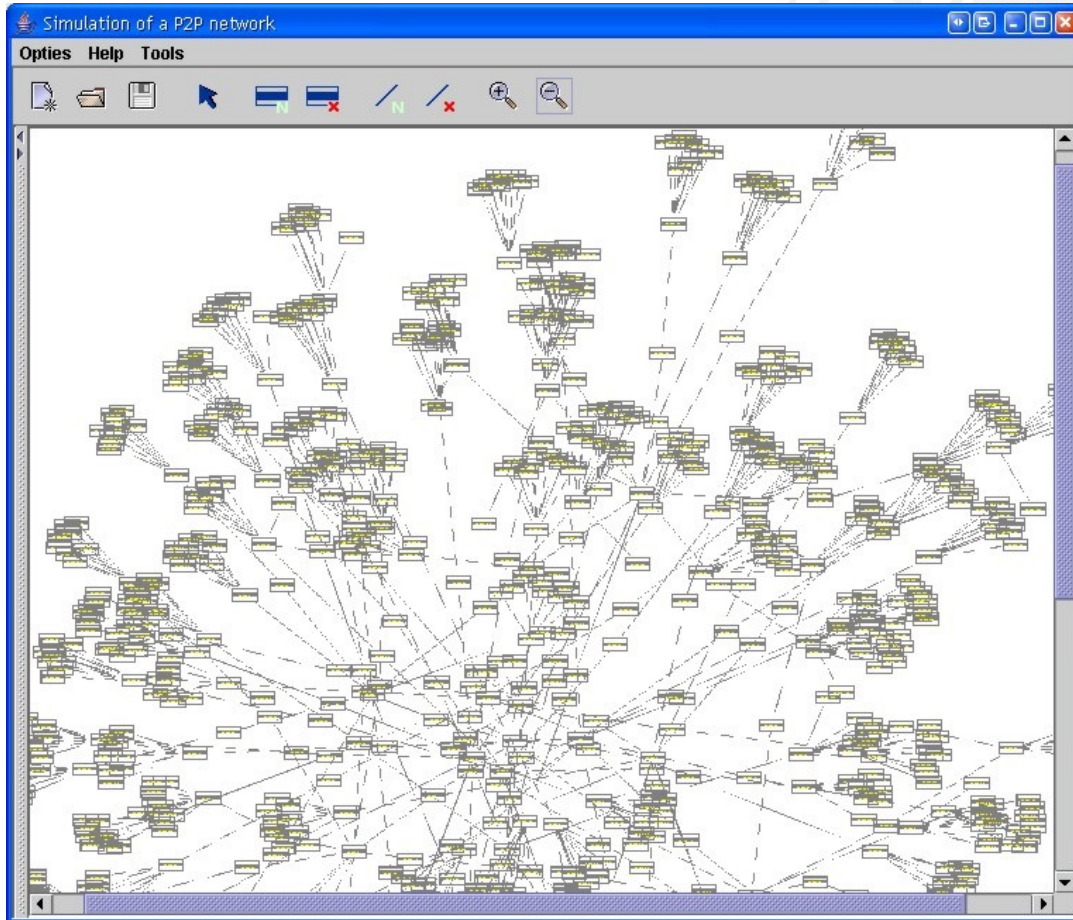

P2P Netzwerk

Anwendungen ...

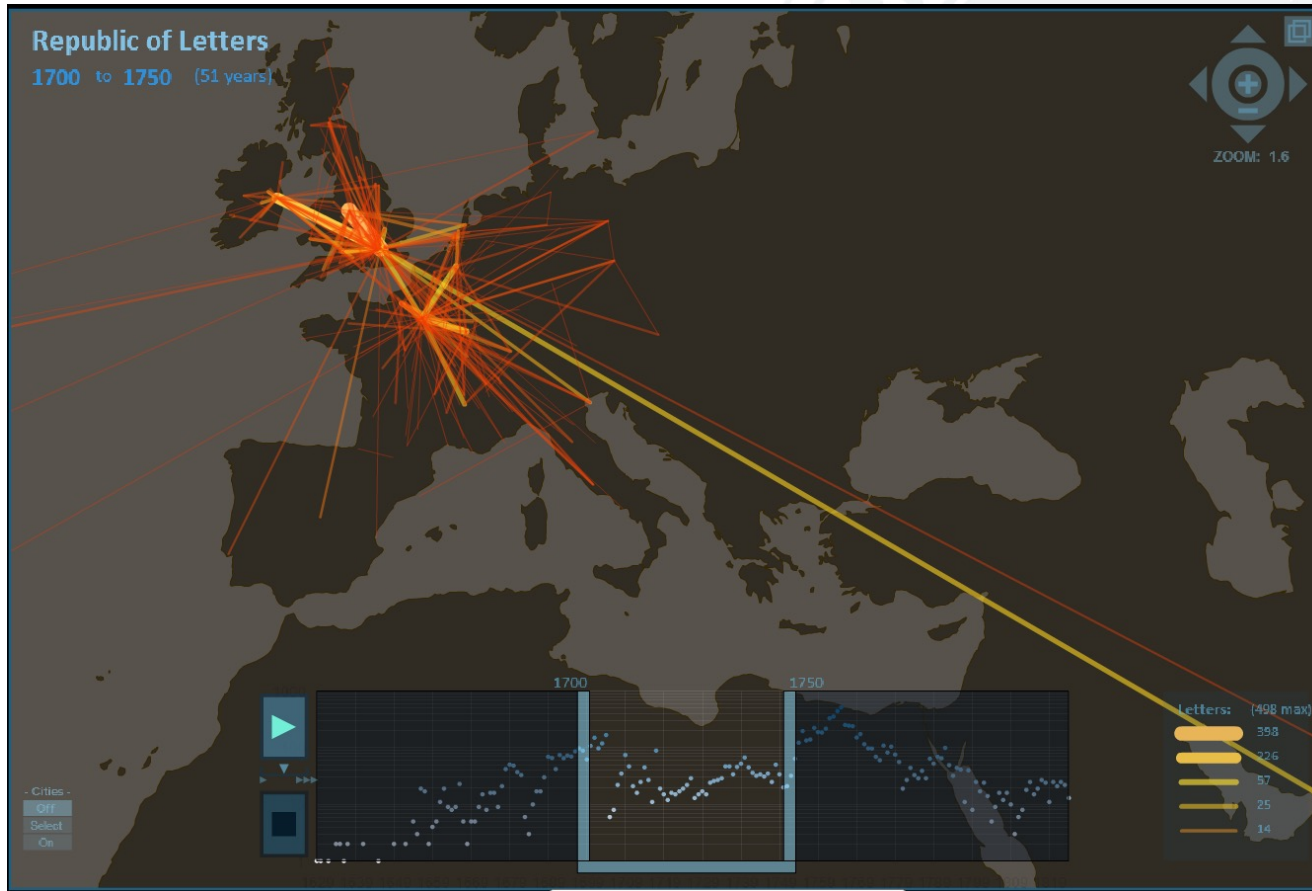

www.stanford.edu/group/toolingup/rplviz/



Anwendungen ...

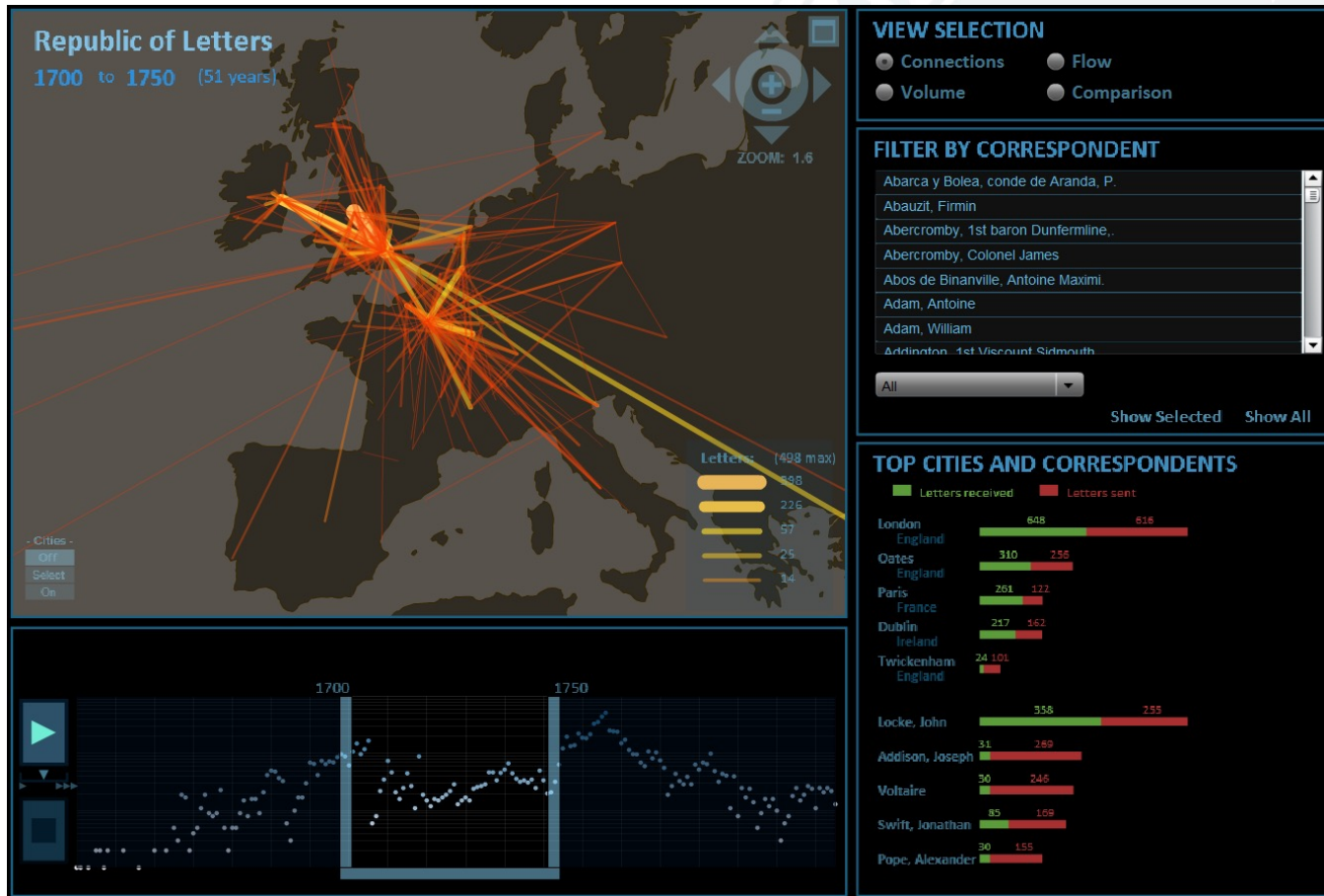

www.stanford.edu/group/toolingup/rplviz/

Anwendungen ...

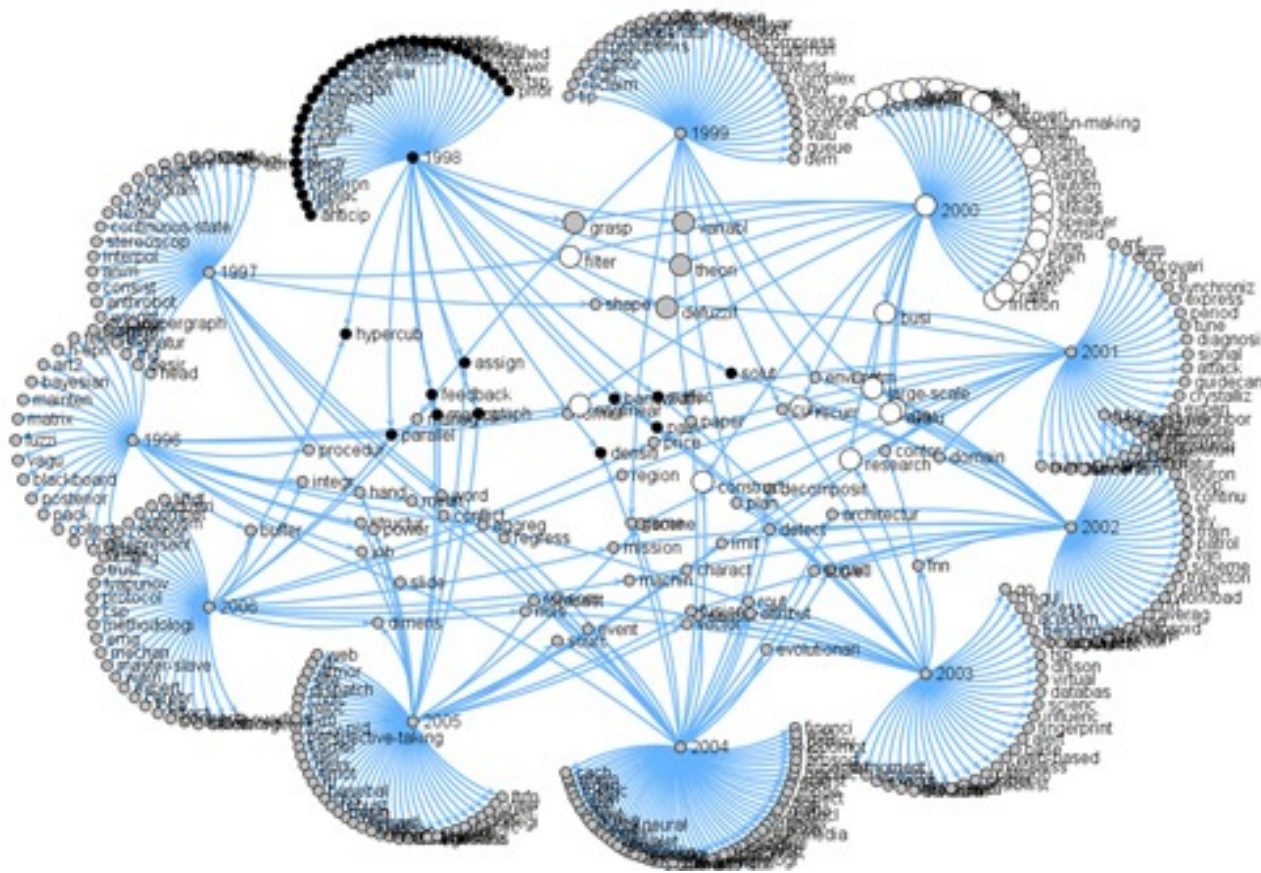

<http://informationandvisualization.de/blog/graphbased-visualization-topic-shifts>

Anwendungen ...

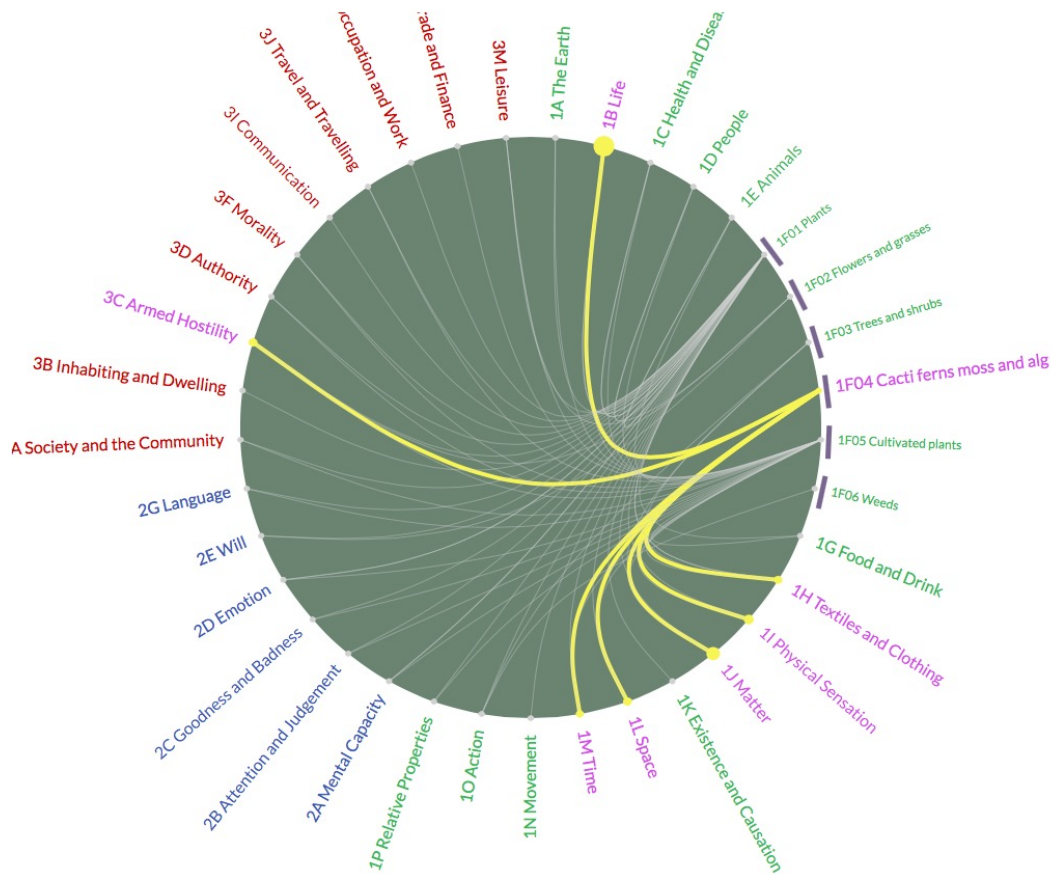

<http://mappingmetaphor.arts.gla.ac.uk>



Weitere Begriffe

Ein ungerichteter, zusammenhängender Graph ohne Zyklen heisst *Baum*.

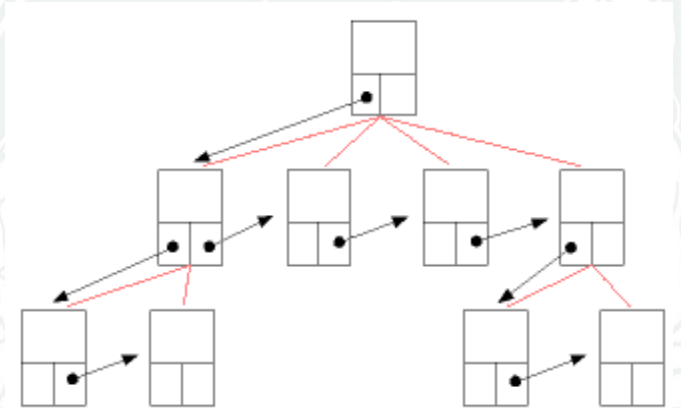

D.h., die *schwarzen Pfeile* im nebenstehenden Diagramm definieren Zeiger nach unserer früheren Definition.

Die *roten Linien* repräsentieren die Kanten im repräsentierten Graphen.

Anwendungen...

Arbre de la ciència, Arbor Scientiae (The Tree of Science), written by Ramon Llull in Rome between 1295 and 1296.



https://commons.wikimedia.org/wiki/File:Houghton_SC.L9695.482ab_-_Ramon_Llull,_1505.jpg

How does the Dewey Decimal system work?

DDC is an hierarchical number system that organizes all human knowledge into ten main categories. These are:

- 000 Computer Science, information and general works
- 100 Philosophy and psychology
- 200 Religion
- 300 Social sciences
- 400 Language
- 500 Science**
- 600 Technology
- 700 Arts and recreation
- 800 Literature
- 900 History and geography

Each main category is then divided into ten sub-categories. For example:

- 500 Science
- 510 Mathematics
- 520 Astronomy
- 530 Physics**
- 540 Chemistry
- 550 Earth sciences and geology
- 560 Fossils and prehistoric life
- 570 Biology
- 580 Plants (Botany)
- 590 Animals (Zoology)



Anwendung: XML

```
<text xmlns="http://www.tei-c.org/ns/1.0"
xml:id="d1">
  <body xml:id="d2">
    <div1 type="book" xml:id="d3">
      <head>Songs of Innocence</head>
      <pb n="4"/>
      <div2 type="poem" xml:id="d4">
        <head>Introduction</head>
        <lg type="stanza">
          <l>Piping down the valleys wild, </l>
          <l>Piping songs of pleasant glee, </l>
          <l>On a cloud I saw a child, </l>
          <l>And he laughing said to me: </l>
        </lg>
```

...



XML as string

```
<kurs>  
  <person>  
    <vorname attr1="value1">Margarita</vorname>  
    <famname attr2="value2">Weber</famname>  
  </person>  
  <person>  
    <vorname attr1="value1">Heike</vorname>  
    <famname attr2="value2">Jurzik</famname>  
  </person>  
</kurs>
```



XML as tree

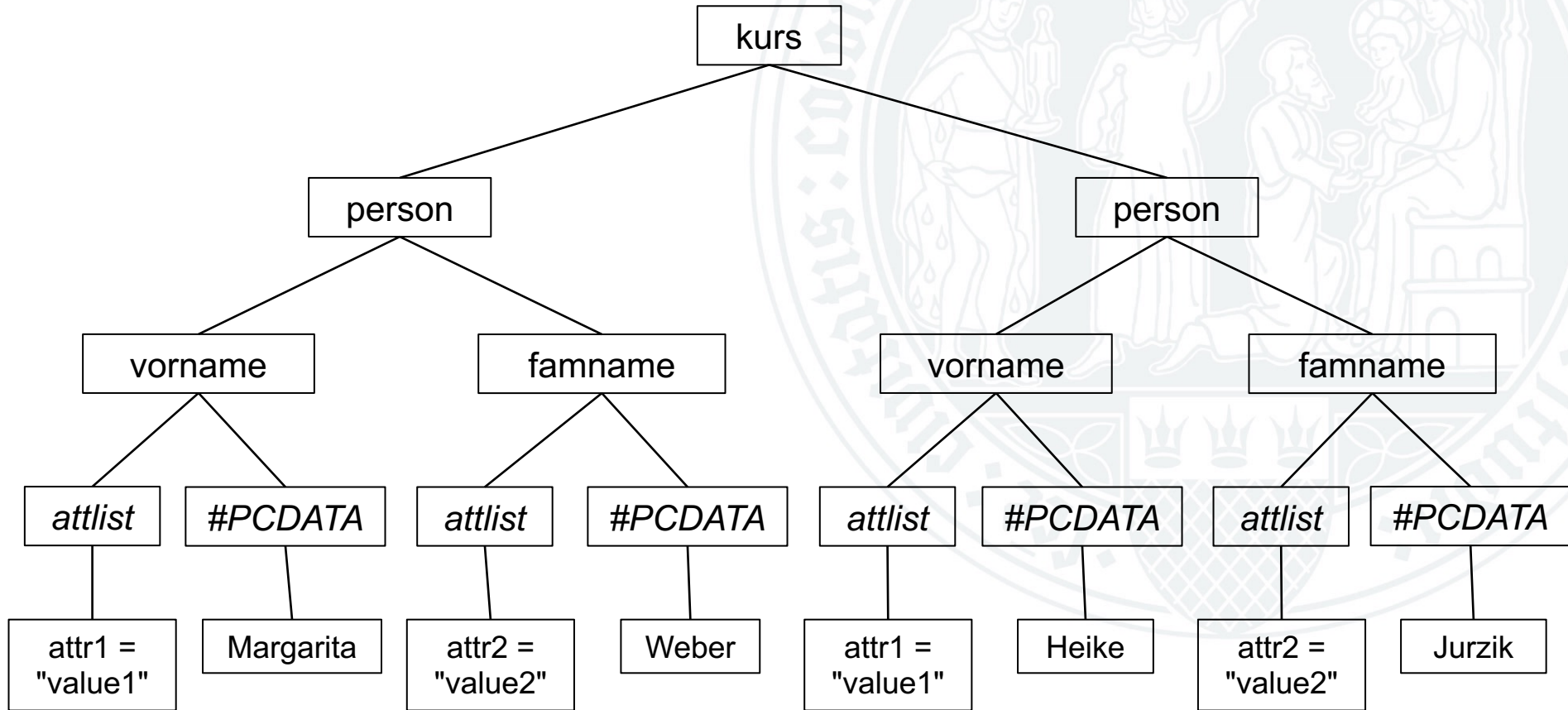

DTD as string

```
<!ELEMENT kurs person>
```

```
<!ELEMENT person vorname  
famname>
```

(actually it is `<!ELEMENT kurs
person+>`)



DTD as tree

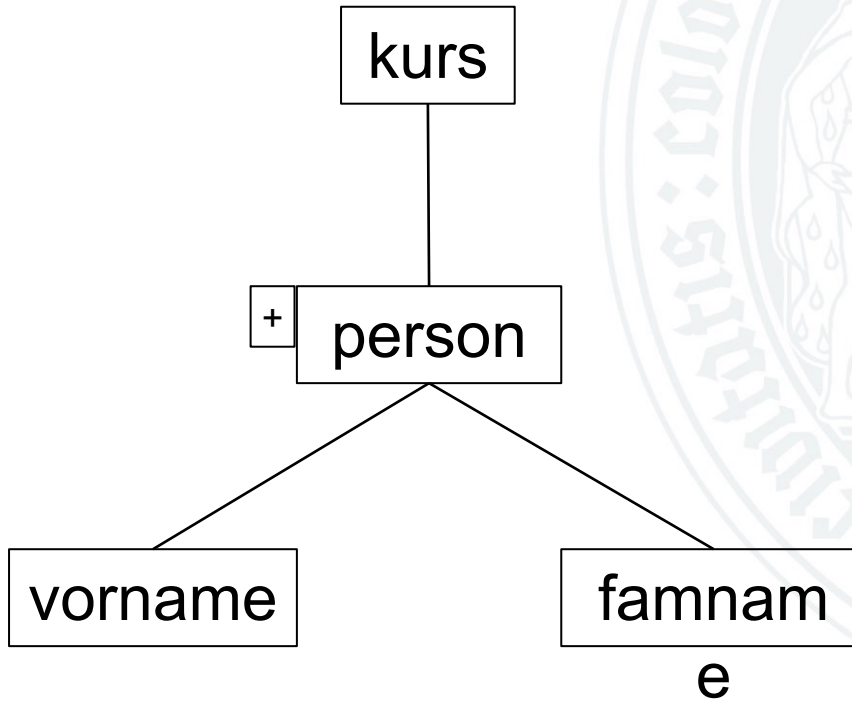

Validation graph traversal

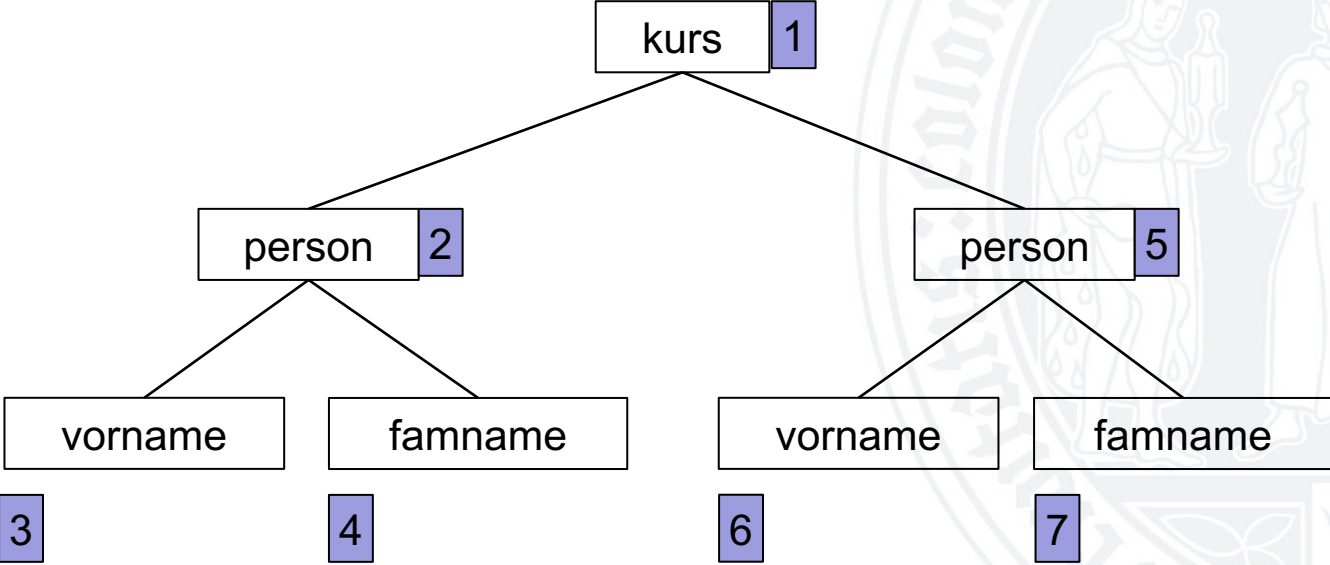

XML

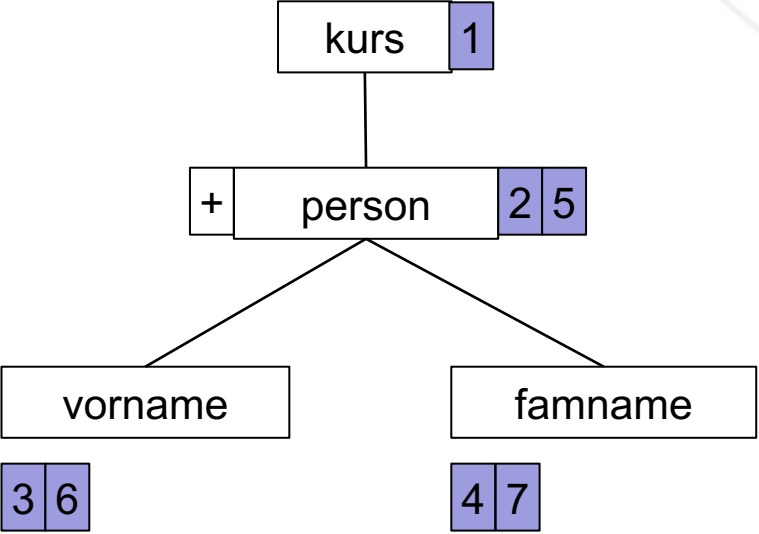

DTD

Was ist Modellierung?

- Kreative/logische Denkprozesse
 - Bedeutung, die durch die Erstellung und Manipulation von externen Repräsentationen erzeugt und ausgehandelt wird.

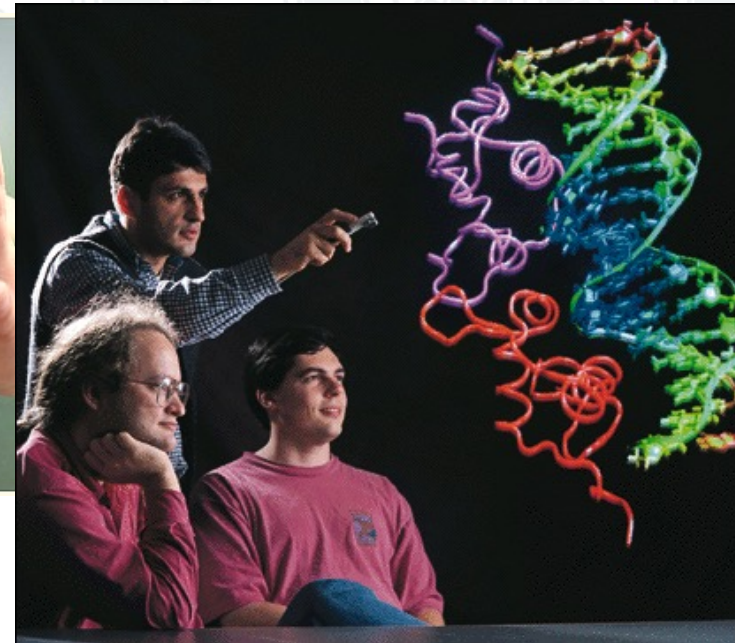
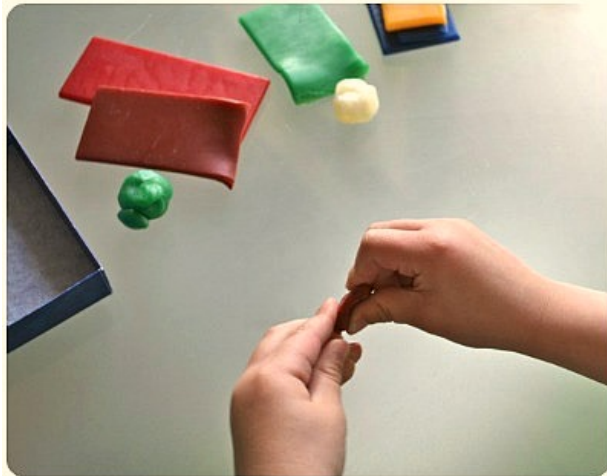

- Als Forschungsstrategie
 - Prozess
 - ForscherInnen macht und bearbeitet externe Repräsentationen (“imaginary concreta”, Godfrey-Smith 2009)
 - Ziel: Verständnis schaffen
 - Quelle: konzeptuelle Objekte und Phänomene

Modellierung in den (digitalen) Geisteswissenschaften

- Digital
 - formal
 - regelbasiert
 - strukturiert
 - diskret
- Praxisbasiert
- Geisteswissenschaften
 - analog
 - kontinuierlich
 - nuanciert
 - hermeneutisch
- Dicke Beschreibungen
- Brücke: Operationalisierung
- Menschliche Untersuchungskonzepte
 - messbar
 - Berechenbar
- machen/ tun